



Equipment for the Foodservice Industry
value + quality + service

Undercounter Refrigeration

CUDR3-72VC



CUDR3-72VC

Features

Features:

- Exterior & interior stainless steel construction
- Environmentally friendly R290 refrigerant
- Heavy duty Embraco compressor
- Self-closing and stay open door
- Efficient refrigeration system
- Recessed door handle
- Removable gasket that is easy to clean and replace
- Casters for easy movement
- Pre-installed shelves

Warranty:

- Two year parts and labour; Five years on compressor. For full warranty details visit <https://www.efifoodequip.com/warranty-info.php>



CUDR3-72VC Specifications

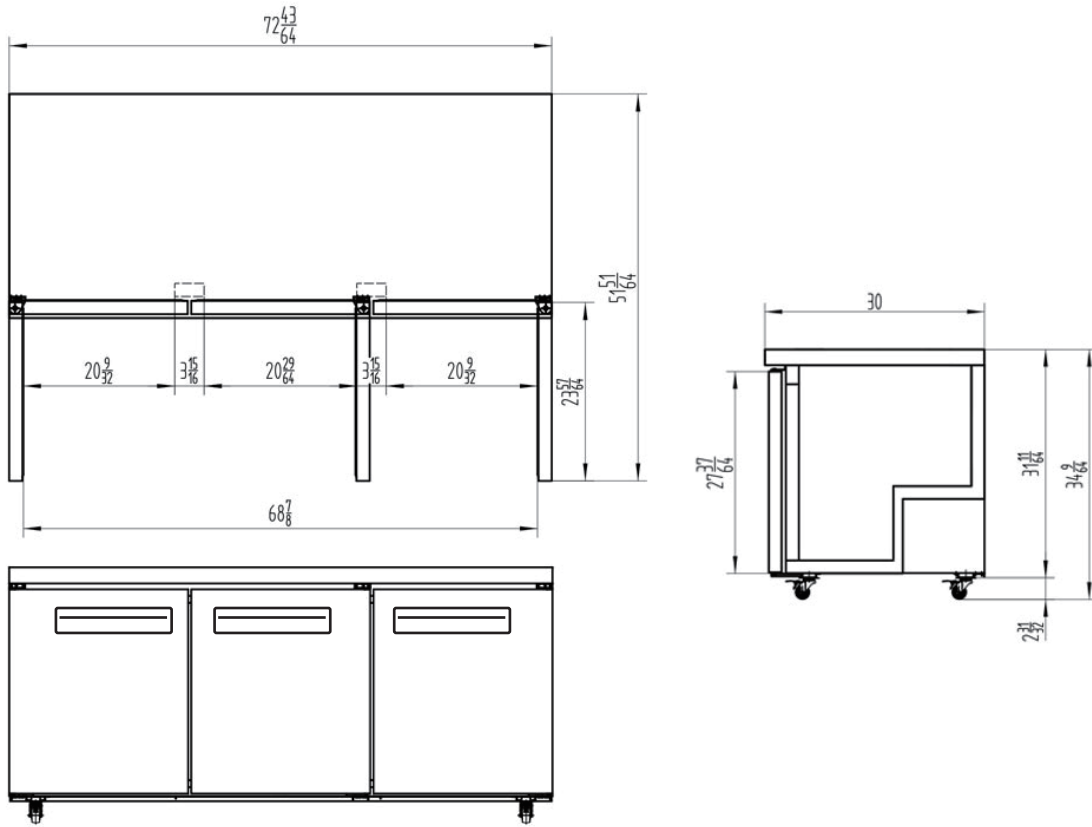

Model	Refrigerant	Doors	Shelves	Dimension (mm) (inch)			HP	Voltage	Amps	Capacity (L) (Cu Ft.)	Net Weight (KG) (LBS)	Temperature Range
				L	D	H						
CUDR3-72VC	R290	3	3	1846	762	868	1/5	115/60	2.8	598	115	1 ~ 8°C
				72.7	30.0	34.1						

Equipped with one NEMA 5-15P plug 

Shipping Information

Crate Dimensions (mm) (inch)			Net Weight (KG) (LBS)	Gross Weight (KG) (LBS)
L	D	H		
1900	831	980	115	143
74.8	32.7	38.6	254	315

Specifications subject to change without notice.